

# Ultrasonic Hardness Tester D10

## Instruction Manual



---

# Content

◆ Safety and Liability.....	4
◆ Statement.....	4
<b>1. Introduction.....</b>	<b>5</b>
1.1 Preface.....	5
1.2 Instrument Introduction.....	5
1.3 Instrument Features.....	6
1.4 Application Range.....	6
1.5 Working Conditions.....	6
1.6 Packing List.....	7
<b>2. Structure Illustration.....</b>	<b>8</b>
2.1 Main Structure and Principle.....	8
2.2 Buttons Illustration.....	9
2.3 Ultrasonic Probe.....	10
2.3.1 Types of Probe.....	10
2.3.2 Motorized Probe.....	11
2.4 Indenter and Indentation.....	12
2.5 Test stand.....	13
<b>3. Technical Features.....</b>	<b>14</b>
3.1 Technical Specification.....	14
3.2 Packing Details.....	15
<b>4. Operation Precautions.....</b>	<b>15</b>
4.1 Preparation and Inspection.....	15
4.1.1 Specimen Request.....	15
4.1.2 System Settings.....	18
4.1.3 Test Settings.....	18
4.2 Measurement.....	18
4.2.1 Instrument Preparation.....	18
4.2.2 Measurement Style.....	19
4.2.3 Result Reading.....	20
4.2.4 Review/print Result.....	20
4.2.5 Writing Style.....	20
<b>5. Special Attention.....</b>	<b>20</b>
<b>6. Operation Illustration.....</b>	<b>21</b>
6.1 Power On.....	21

---

6.2Power Off.....	21
6.3Interface and Buttons.....	21
6.3.1Interface Illustration.....	21
6.4 Menu Structure.....	23
6.5Test Setting.....	24
6.5.1Set of Calibration.....	25
6.5.2Set of Scales.....	25
6.5.3Start Measuring.....	25
6.5.4Set of Test Numbers.....	25
6.5.5Set of Error.....	25
6.5.6Set of Batch Measurement.....	25
6.5.7 Set of Measurement Time.....	25
6.6System Setting.....	26
6.6.1Set of Language.....	27
6.6.2Set of Voice.....	27
6.6.3Battery Manage.....	27
6.6.4Display Setting.....	27
6.6.5Date Setting.....	27
6.6.6Factory Reset.....	27
6. 7Memory Setting.....	28
6.7.1Auto Save Setting.....	28
6.7.2Review Results.....	29
6.7.3On-line Operation.....	29
6.7.4Partial Delete.....	29
6.7.5 Delete All.....	29
6.8Printing Setting.....	29
6.8.1Partial Print.....	29
6.8.2Print All.....	29
6.9Calibration Steps.....	30
6.10. Error and repeatability request for ultrasonic hardness tester in standard of JB/T9377-2010.....	33
6.11About Battery.....	35
6.12. Data Transmission.....	35
<b>7. Troubleshooting.....</b>	<b>35</b>
<b>8. Maintenance.....</b>	<b>36</b>
<b>9. Warranty Attention.....</b>	<b>37</b>
<b>10. Storage/Transportation Attention.....</b>	<b>37</b>

---

## ◆ Safety and Liability

This manual contains important information on the safety, use and maintenance of instrument. Read through the manual carefully before the first use of the instrument. Keep the manual in a safe place for future reference.

## ◆ Safety Instructions

⚠ Danger: This symbol indicates a risk of serious or fatal injury in the event that certain rules of behavior are disregarded.
--

⚠ It is a kind of precision instrument, handle with care and avoid any serious shaking to damage internal components.

⚠ Indenter of instrument is diamond, absolute hardness in nature, do not use it to scratch and damage precious objects.

⚠ After a measurement, take off indenter about one second, then make a new measurement. Otherwise it can not make resonance between indenter and specimen in a short time.

⚠ After finished use, please keep instrument in carrying case, avoid any damage by accident.

⚠ Do not disassemble main unit and probe, otherwise no service to the instrument

⚠ Do not use the instrument under inflammable air environment, otherwise will lead to fire or explode.

⚠ About battery, • Please only use the battery supplied by original manufacturer; • Do not disassemble battery; • when install battery, aim correctly socket to avoid wrong connection of battery negative and positive; • Do not throw battery in fire or heating; • do not put battery in water or touch water; • do not use battery in case of deformation; • turn off instrument before replace battery, do not take off battery during power on status; • battery is installed well before leaving factory, do not make modification if no special situation.

⚠ About recharger: • keep it in dry status; • Avoid short circuit, otherwise will damage it; • do not touch it by wet hand, otherwise will get an electric shock;

## ◆ Statement

• Without the prior written permission of the Company and its subsidiaries for all products related to the contents of this manual may be reproduced in any form spread, or in a retrieval system, or translated into other languages are stored.

• The Company reserves the right to change the specification contained hardware and software specifications without prior notice.

•Every effort was made to ensure the accuracy and integrity of information contained in the instructions, if any, flaws and errors, reflected to us, we will revise the next edition, we would appreciate it!

## 1. Introduction

### 1.1 Preface

Thank you for purchasing ultrasonic hardness tester D10, the present execute standards DIN 50159-1-2008; ASTM-A1038-2005; JB/T 9377-2010 and JJG-654-2013. It is a precision hardness-comparison instrument applied with ultrasonic contact impedance principle. To avoid any unnecessary damage and loss, please read this Manual carefully before operation and keep it safety for further reference.

### 1.2 Instrument Introduction

At present, there are kinds of methods for hardness measurement, commonly used like Brinell, Rockwell, Vickers, Leeb, etc. Rockwell and Brinell with heavy loading force and big indentation, lead to serious destructive on sample surface. Vickers apply optical measurement, but only professional technicians can smoothly operate, impossible to measure hardness of heavy work piece, installed machinery and permanently assembled parts.

Ultrasonic hardness tester apply ultrasonic contact impedance method to do comparative hardness measurement for testing pieces, with advantages of high accuracy, efficiency, portable, easy operation and nondestructive measurement. As shown in figure 1-1.

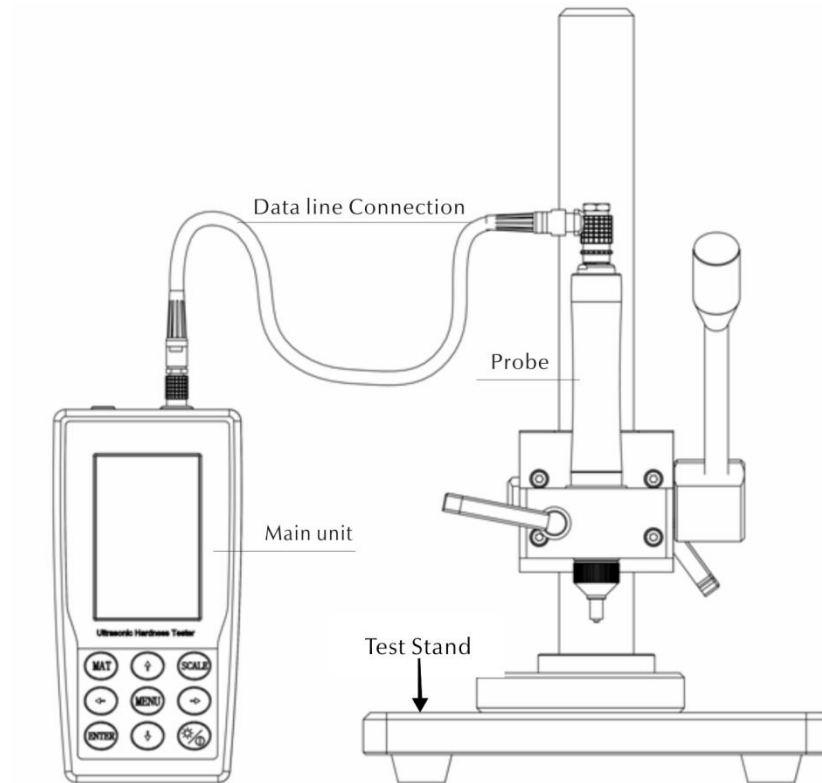

Fig 1-1

---

### 1.3 Instrument Features

- Perfect Accuracy:  $\pm 3\% \text{HV}$ ,  $\pm 3\% \text{HB}$ ,  $\pm 1.5 \text{HR}$ .
- Microscopic Indentation: Only high-power microscope can observe the indentation.
- Quick Measurement: Result in 2 seconds.
- Large LCD Display: Directly display measurement result, times count, maximum, minimal, average and deviation.
- Mass Storage: Save 2000 groups measurement data.
- Simple Calibration: Save 20 groups calibration data for recall.

### 1.4 Application Range

- Hardness measurement of flange edge and gear root stamping, mold, sheet, surface hardened tooth and gear groove, and taper part ;
- Hardness measurement of axis, thin-wall pipe and container
- Hardness measurement of wheels and turbine rotor
- Hardness measurement of bit blade
- Hardness measurement of welding parts
- Measurement of certain aperture depth deep dent, convex mark greater radian, irregular plane
- Hardness measurement of most ferrous metal, non-ferrous metals and other alloys in industrial production.

### 1.5 Working Conditions

Working temperature:  $-10^{\circ}\text{C} \sim 40^{\circ}\text{C}$

Storage temperature:  $-20 \sim +60^{\circ}\text{C}$

Working Relative Humidity:  $\leq 85\%$

Without vibration, no corrosive medium and serious dust in the surrounding environment

## 1.6 Packing List

Standard Delivery of D10					
Item	Commodity	Model	Code	Quantity	Remark
1	Instrument Panel	/	/	1	2-Year Warranty
2	2Kg Manual Probe	HP-2K	1-321	1	1 Year Warranty
3	Probe Cable	—	1-301	1	Consumables, No warranty
4	Recharger	—	1-901	1	Consumables, No warranty
5	Battery	—	1-911	1	Consumables, No warranty
6	Screw driver	—	1-951	1	Consumables, No warranty
7	Carry Case	—	1-991	1	Consumables, No warranty
8	Warranty Card	—	1-981	1	Consumables, No warranty
9	Quality Certificate	—	1-971	1	Consumables, No warranty
10	Operation Manual	—	1-961	1	Consumables, No warranty
11	Calibration Certificate	—		1	Consumables, No warranty
D10 Optional Accessory					
Item	Commodity	Model	Code	Quantity	Remark
12	1Kg Manual Probe	HP-1K	1-311	1	1 Year Warranty
13	5Kg Manual Probe	HP-5K	1-331	1	1 Year Warranty
14	10Kg Manual Probe	HP10K	1-341	1	1 Year Warranty
15	Motorized Probe	/		1	1 Year Warranty
16	Testing Stand	MU-100	1-301	1	Consumables, No warranty
17	Testing Stand	MU-200	1-201	1	Consumables, No warranty
18	Ultrasonic Hardness Block	(28~35)HRC	1-611	1	Consumables, No warranty
19	Ultrasonic Hardness Block	(38~43)HRC	1-621	1	Consumables, No warranty
20	Ultrasonic Hardness Block	(48~53)HRC	1-631	1	Consumables, No warranty
21	Ultrasonic Hardness Block	(58~63)HRC	1-641	1	Consumables, No warranty
22	Ultrasonic Hardness Block	(180300)HV5	1-651	1	Consumables, No warranty
23	Ultrasonic Hardness Block	(450550)HV5	1-661	1	Consumables, No warranty
24	Ultrasonic Hardness Block	(650750)HV5	1-671	1	Consumables, No warranty
25	Plan Support Ring	—	1-511	1	Consumables, No warranty

26	Small Cylinder Support Ring	—	1-521	Consumables, No warranty
27	Big Cylinder Support Ring	—	1-531	Consumables, No warranty
28	Standard Probe Protector	—	1-711	Consumables, No warranty
29	Deep-Hole Probe Protector	—	1-721	Consumables, No warranty

## 2. Structure Illustration

### 2.1 Main Structure and Principle

As shown in figure 2-1, 2-2 (Front view and back view of D10)

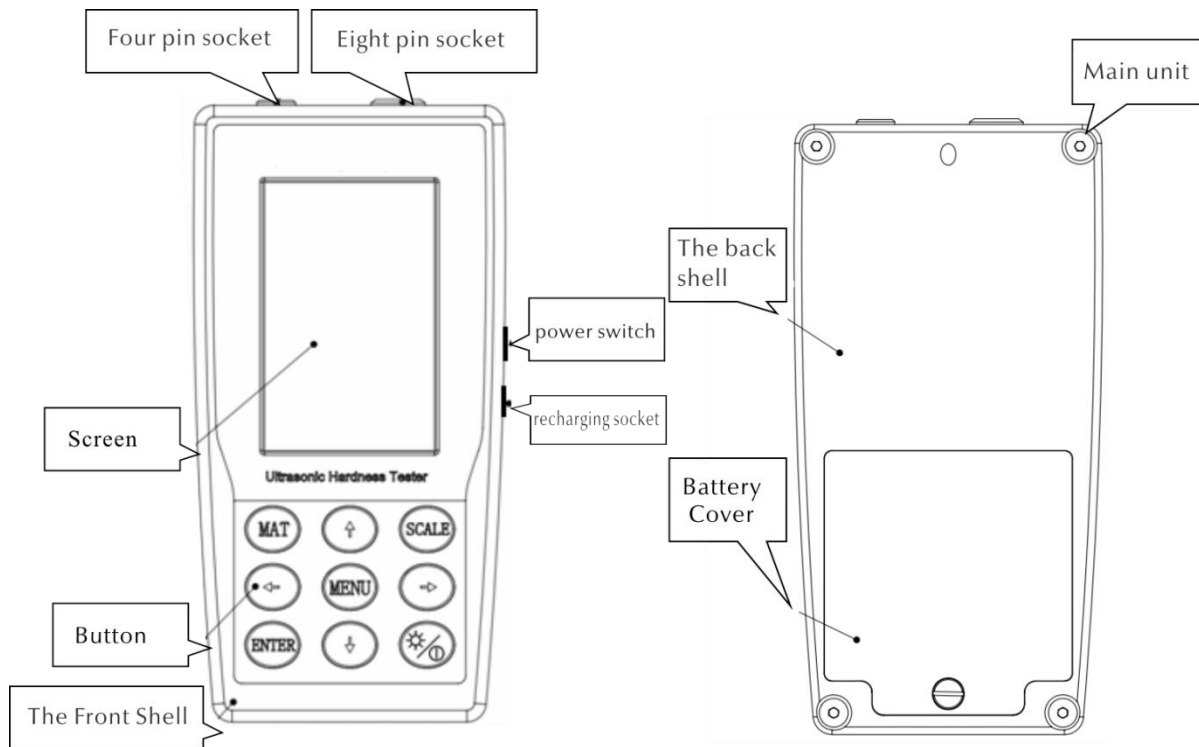

Fig 2.1

Fig 2.2

- The main unit is connected through an 8-pin data cable and ultrasonic probe, as shown in figure 1-1.
- The principle of ultrasonic hardness tester: ultrasonic contact impedance method and Young's elastic modulus of metal.

- theory equality of ultrasonic hardness testing EQ1:

$$\Delta f = f(E_{\text{eff}}, A); \quad HV = F/A$$

- $\Delta f$  = Frequency shift
- $A$  = Indentation area
- $E_{\text{eff}}$  = Effective elastic modulus
- $HV$  = Vickers hardness value
- $F$  = Force applied in the hardness test

EQ1

Remark:

As can be seen in EQ 1, the frequency shift not only depends on the size of the contact area but also on the elastic module of the materials in contact. To allow for differences in Young's modulus, the instrument has to be calibrated for different groups of materials. After calibration, the UCI method can be applied to all materials, which have the corresponding Young's modulus.

## 2.2 Buttons Illustration

Shown in figure 2-1:

- **【MAT】** ——Start calibration in calibration interface; select calibration group in calibration selection interface; Short cut of calibration selection interface in main interface; as selected printing data in printing interface  
 ↑
- **【SCALE】** ——Select hardness scale in main interface; positioning measurement data in displaying interface; in delete interface, delete selected data;
- **【MENU】** ——For confirmation in main interface and calibration interface; In others interface, used as back to previous menu and quit
- **【ETR】** ——Start measurement in main interface; used as confirmation in others interface;
- **【↑】** ——Upward direction and increasing

- **【↓】** ——Downward direction and decreasing
- **【→】** ——Move right, adjust contrast of screen-lighter
- **【←】** ——Move left, adjust contrast of screen-darker
- —  ——Power on/off, back light turn on/off, keep press is power on/off, press once is back light on/off.

**2.3 Ultrasonic Probe**

**2.3.1 Types of Probe**

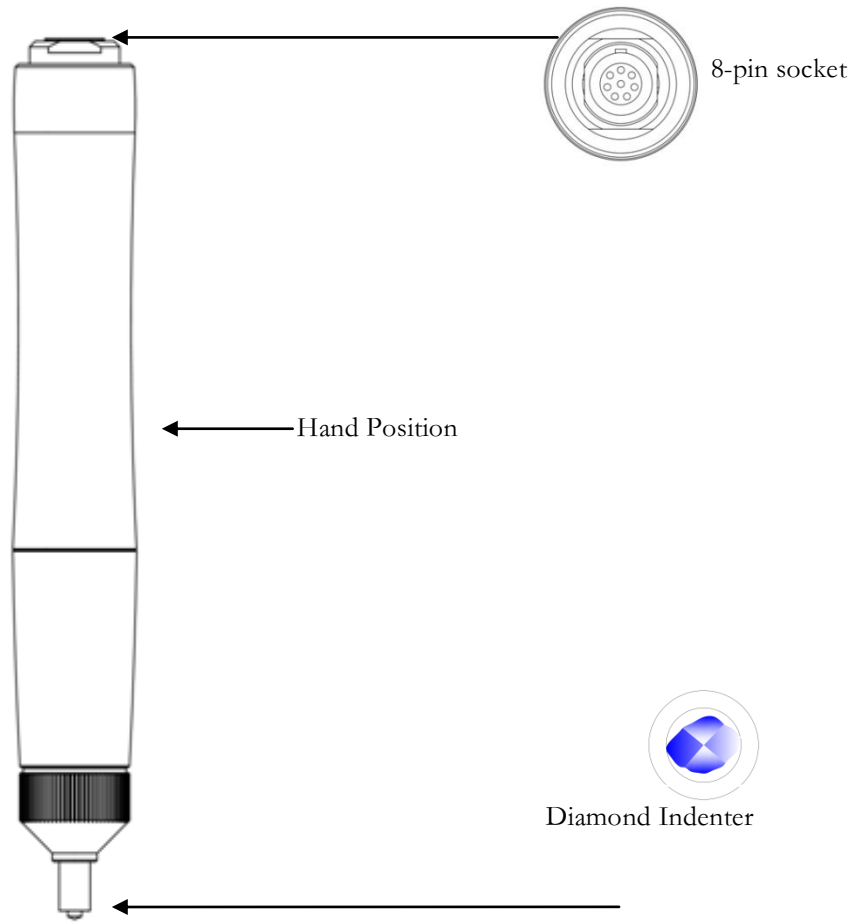

F 2-3

Probe Specifications:

Table one

Probe Type	HP-1K	HP-2K	HP-5K	HP-10K
Select	Optional	Standard	Optional	Optional
Loading Force	10N	20N	50N	98N
Probe applications	Ion-nitrided dies and molds, forms, thin-walled parts, bearings, gear side and the inner wall of pipes	Ion-nitrided dies and molds, forms, thin-walled parts, bearings, gear side and the inner wall of pipes	Measurement in grooves, on gear tooth flanks and roots	Small forgings, weld inspection, HAZ, lower roughness requirements

2.3.2 Motorized Probe

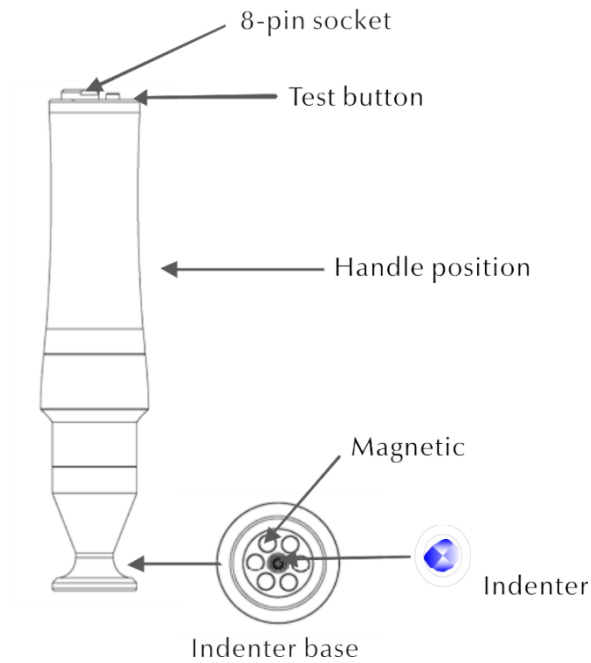

Fig.2-3-3

## Technical Data of Motorized Probes

Table 2-2-4

Probe Type	MP-300	MP-500	MP-800	MP-1000
Code #	2-221	2-231	2-241	2-251
Selection	Optional	Optional	Optional	Optional
Test force	3N	5N	8N	10N
Diameter	46mm	46mm	46mm	46mm
Length	197.5mm	197.5mm	197.5mm	197.5mm
Oscillating rod diameter	3.7mm	3.7mm	3.7mm	3.7mm
Min weight of specimen	0.3kg	0.3kg	0.3kg	0.3kg
Min thickness of specimen	2mm	2mm	2mm	2mm

### 2.4 Indenter and Indentation

Ultrasonic indenter is a  $136^\circ$  diamond indenter, showed a prism indentation on samples; the size of indentation is different based on the specimen materials. The shape of indentation is the same as Vickers and need high power microscope to observe. As shown in figure 2-3-2-1, 2-3-2-2.

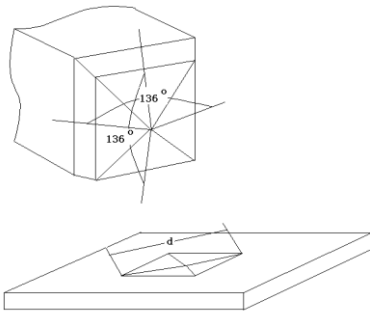

F2-3-2-1

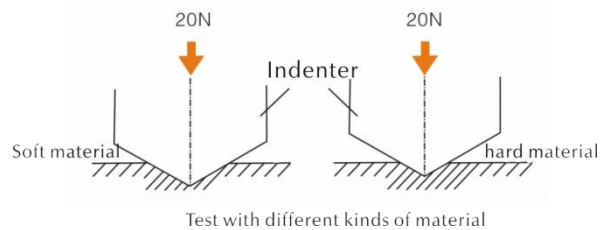

F2-3-2-2

● Indentation depth (h) and diagonal length mean value (d) of D10 probes decreases along with hardness value increasing. Table 2-3-2

Specific hardness value by different probes of D10 with its indentation depth (h, $\mu\text{m}$ )				
	HP-1K	HP-2K	HP-5K	HP-10K
800HV	7	10	15	22
600HV	8	11	18	25
300HV	11	16	25	36
Specific hardness value under different probes of D10 with its dialogue length mean value (d, $\mu\text{m}$ )				
	HP-1K	HP-2K	HP-5K	HP-10K
800HV	48	68	108	152
600HV	56	79	124	176
300HV	78	111	176	249

## 2.5 Test stand

• In order to maximally eliminate human operation error, install ultrasonic hardness tester in testing stand, can easily obtain stable testing results testing stand is an auxiliary device can improve calibration accuracy.

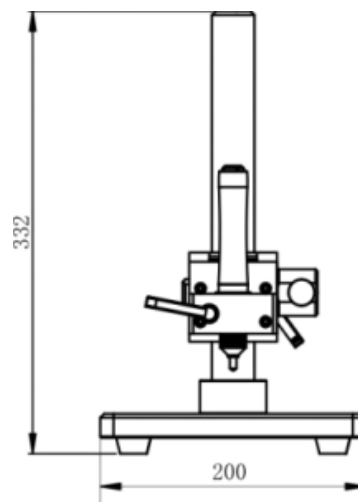

2.4

---

### 3. Technical Features

#### 3.1 Technical Specification

- Measurement Ranges:

HRC: 20.3~68;

HRB :41~100;

HRA: 61~85.6

HV: 80~1599

HB: 76~618

Tensile strength: 255~2180N/mm<sup>2</sup>

- Measuring Directions: support 360° ( As long as the probe is perpendicular to the measured object then can be measured )
- Hardness Scale: HV, HRC, HRA, HRB, HB , etc.
- Battery: 4.2v, 4800MAH rechargeable lithium battery
- Recharging Time: Standard recharging time is 8H, in order to lengthen using life, make sure each recharging time not less than 4H
- Standby time; 10 hours (No backlight)
- Connected with printer to print the measuring data or transfer the measuring data through super terminal to computer, read part 6.8 and 6.11 for details.
- Saving 1000 groups of measuring data and 20 groups of calibration data
- Can calculate average value of the specimen with uneven hardness distribution through gathering multiple-points measurement.
- It is fast, simple operation and perfect accuracy for batch measurement of small specimen on production lines if matching the optional test stand.
- Without damage on the specimen surface , convenient operation, good stability, perfect accuracy.

---

### 3.2 Packing Details

Main unit: 162×81×31mm

Probe: Φ22×153mm

Main unit and probe: 755g

## 4. Operation Precautions

### 4.1 Preparation and Inspection

#### 4.1.1 Specimen Request

- *Minimum Thickness*

*Ultrasonic hardness tester uses Vickers diamond indenter, so the calculation formula of Vickers hardness tester is still applicable in ultrasonic hardness tester. Thin coatings or surface layers on bulk material must have a minimum thickness (t).*

1) Penetration depth of the Vickers diamond pyramid for a certain hardness (in HV) and test load (in N) is shown in EQ2

$$h=0.062\sqrt{\frac{F}{HV}} \quad (4-1-1)$$

h : mm, test load F : N

Mini thickness of at least on 10 times of the indentation depth of indenter used

$$t\geq 10h \quad (4-1-2)$$

From (4-1-1) and (4-1-2) , we can get

$$\text{Mini thickness } t\approx 0.62\sqrt{\frac{F}{HV}} \quad (4-1-3)$$

T: mm; test load F: N

From formula 4-1-3, we can get below table for minimal thickness (Table 4-1-0)

Specific hardness value (HV) with different probes request minimal thickness as follows (μm)				
	HP-1K	HP-2K	HP-5K	HP-10K
800HV	69	100	150	220
600HV	79	110	180	250
300HV	112	160	250	350

Fig. 4-7 Specimen thickness, testing force and hardness value

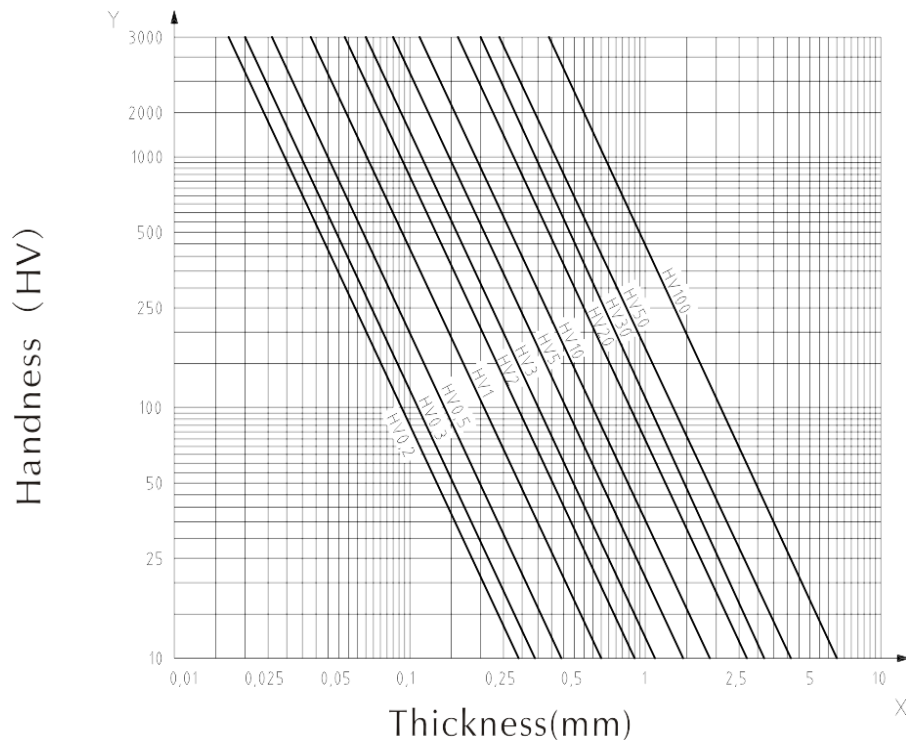

#### F4.7 Specimen thickness, testing force and hardness value (HV0.2~HV100)

**Note: According to** Ultrasonic Contact Impedance Method (UCI Method), probe must contact with test piece then get resonating, and get hardness value, so the mini thickness of Vickers hardness value only apply on big testing pieces or surface.

2)From above analysis, all the probes request coating layer or surface layer less than 1mm, but to small pieces, when thickness less than 15mm, the hardness value will change if resonance.

Most vibration is the elastic oscillation; we can take some actions to restrain. Put the piece on big metal, rubber and oil can restrings elastic wave, but recommend least 2-3mm, size not less than 5X5mm.

**●Surface roughness of test piece**

The applied test force (that is, the selected UCI probe) must not only match the application but also the surface quality and roughness of the material. While smooth, homogeneous surfaces can be tested with low test loads, rougher and coarse-grained surfaces require test loads as high as possible. However, the surface must always be free of any impurities (oil, dust, etc.) and rust.

The surface roughness should not exceed 30 % of the penetration depth ( $Ra \# 0.3 \ 3 \ h$ ) with:

Probe	HP-1K(10N)	HP-2K(20N)	HP-5K(50N)	HP-10K(98N)
Ra	$Ra < 2.5\mu m$	$Ra < 5\mu m$	$Ra < 10\mu m$	$Ra < 15\mu m$

**●Weight of test piece and testing method as fig4-1-2**

Weight	>300g	100 ~ 300g	10 ~ 100g
Auxiliary	Directly test	Support rings	Coupling

- Test pieces with curved surfaces may be tested on either the convex or concave surfaces providing that the radius of curvature of the specimens is matched to the appropriate probe and probe attachment in order to ensure a perpendicular positioning of the probe
- When the specimen is plate, long rod or curved pieces, even if the weight and thickness are enough, still will cause the specimen's instability deformation, finally lead to measure a wrong data. So must strengthen or support for the back part of the test point. As for deep hole with a certain aperture, it will be measured conveniently as long as groove can change the deep-hole probe protective cap

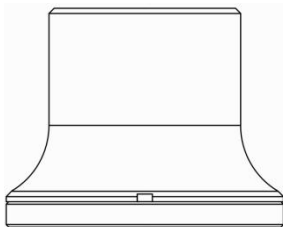

Plan support ring (#882-511)

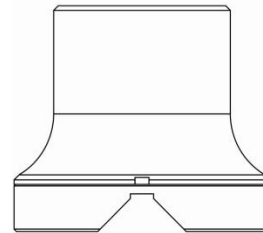

Small cylinder support ring (#882-521)

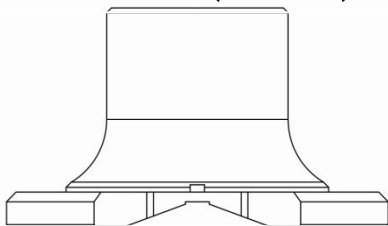

Big cylinder support ring (#882-531)

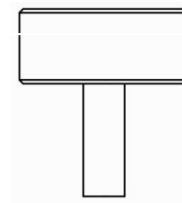

Deep hole probe protector (#882-721)

F4-1-1

## 4.1.2 System Settings

See part 6.6 for details

## 4.1.3 Test Settings

See part 6.5 for details

## 4.2 Measurement

### 4.2.1 Instrument Preparation

● Connected the bending end plug of 8-pin data cable with the 8pin socket of probe, aligned with the groove's positions then gently insert . Hearing "click" sound that has been inserted in place as shown in figure 4-2-1-1; at the same time, connected the other side of 8pin data cable with the 8pin socket of main unit of ultrasonic hardness tester. Aligned with the groove's positions and then gently insert .Hearing "click" sound that has been inserted in place as shown in figure 4-2-1-2.

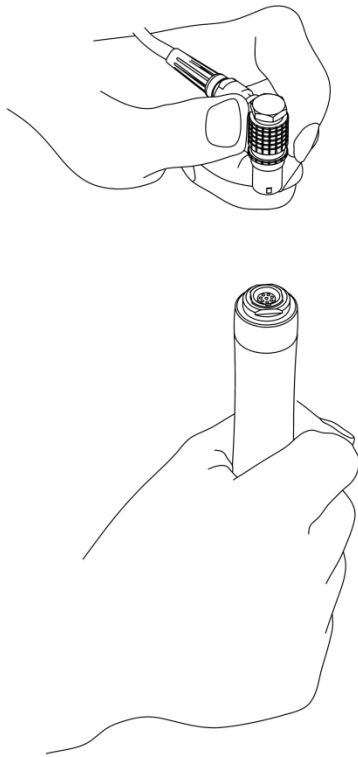

Fig 4-2-1-1





图4-2-1-2

● Press the power button  gently, the power supply is switched on. Then go into the main interface, click **SCALE** button to select measurement scale and then press **ETR** button, when showing measuring mark  , then hand the probe in vertical to pressure on specimen.

● Before the formal measurement of specimen, please inspect the instrument matching with the special ultrasonic hardness blocks, just to check the permitted error and repeatability of the measured number.( in the vertical, pressure to the hardness block 5 times, get the average values compared with the number of hardness block, check whether the error and repeatability have exceeded the standard or not . the user could calibrate by themselves if exceeding.

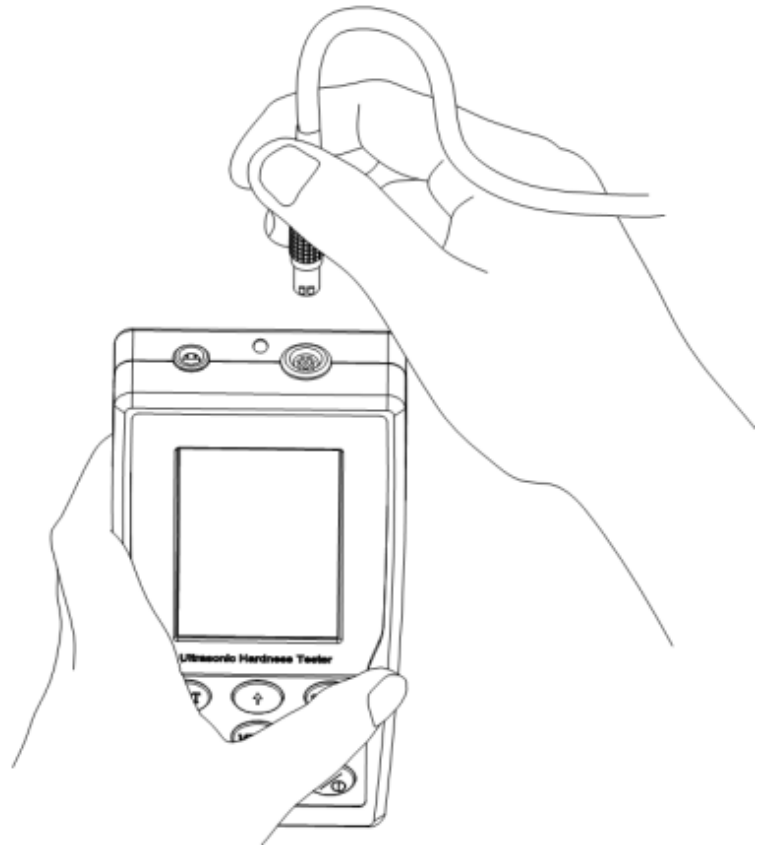
#### 4.2.2 Measurement Style

Hold the middle position of the probe, keep the probe and the measured surface in vertical position, then evenly & downward press the probe vertically until the probe protective cap against the specimen, as shown in figure 4-2-2-1, hold this movement around 2 seconds, then you will hear a “beep” sound, indicating that the probe and the measured object coupling end, and the measuring values are shown in the testing display area. The first measurement is not included in measurement. The next action is to move the probe in another point of specimen, hold the middle position of the probe, keep the probe and the measured surface in vertical position, then evenly & downward press the probe vertically until the probe protective cap against the measured object, hold this movement around 2 seconds, then you will hear a “beep” sound, indicating the first measurement finished. Then repeat this action 4 four times, finally you could hear a “beep” sound , the tested result shown automatically in figure 4-2-2-2,measurement completed.Results are stored in the storage settings→results display(figure 4-2-2-2 S0025 means the tested data was saved in 25 groups).

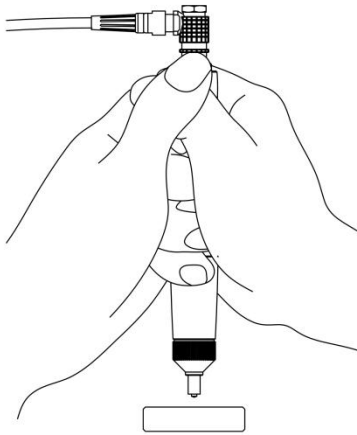

Fig 4-2-2-1

UCI		00:42	
Tester		F: 20N	
Times: 05-05		S: 0025	
Calibration-14			
ASTM			
<b>35.9 AVE HRC</b>			
(01)	35.7	MAX:	36.2
(02)	35.5	MIN:	35.5
(03)	36.2	AVE:	35.9
(04)	36.2	HV :	339
(05)	35.7	HB :	322
(06)	0.0		

Fig 4-2-2-2

Note: Above description is for manual probes, when use motorized probe, make sure probe vertically contact with specimen surface, then press red start button, it will start auto measurement. Then change a test position, please also select motorized probe in main unit before measuring.

---

### 4.2.3 Result Reading

Calculate the average value of a plurality testing points as a measuring data.

### 4.2.4 Review/print Result

The specific setting method for 6.7 and 6.8

### 4.2.5 Writing Style

The instrument has HV, HB, HRC, HRB, HRA5 scales, hardness value showed before hardness symbols, a few KGF probe behind hardness symbols, numerical plus UCI indicates the final and correct writing result of Ultrasonic hardness tester, such as 700HV2UCI---indicating the measuring data is 700HV based on using the probe with 2kgf testing force of Ultrasonic hardness tester.

## 5. Special Attention

- Before the replacement of different probe, please turn off the power of main unit then operate .
- Please press ETR button before measurement ,then keep the probe and the specimen in vertical position to be operated .
- If long time no use, please recharge before reusing;
- Press MEMU button to stop if this set of measurement doesn't want to be continued. If you would like to restart measurement, you could press ETR button
- When connected the probe with the data cable or main unit with data cable, must operate according to the previous steps, aligned with the groove's positions and then gently insert, otherwise the internal pin of plug connected with data line may be crooked and damage.
- Five measurement taken in an area of approximately 645mm<sup>2</sup> shall constitute one test. If the material being tested is considered to be inhomogeneous, then measurements or more shall be made to constitute one test.
- Because the ultrasonic hardness probe is precision components, should pay special attention to protection during measurement, do not hit any part of the probe. The operation method is correct or not will directly affect the measuring accuracy. The correct method is, use two hands to fix the probe, pressure is applied to the direction and object vertically, To avoid the change of pressure, please make sure to keep your hand not moving and shaking. In order to avoid scratching the specimen by probe and the probe abrasion by itself, you must lift the probe vertically after one measurement time.
- *Temperature*—The temperature of the test piece may affect the results of the UCI hardness test. However, if the probe is exposed to elevated temperature for only the time of measurement, measurements are possible at temperatures higher than room temperature, without influencing the performance of the UCI instrument.

---

## 6. Operation Illustration

### 6.1 Power On

Slide power switch on the right side of main unit, the instrument displayed in figure 6-1.

- The interface includes ultrasonic hardness tester model D10; serial number SN

- The serial number of the machine with the warranty card series

number should be accordant, otherwise the instrument couldn't enjoy free warranty treatment.



Fig 6-1

### 6.2 Power Off

In any displaying state, you can slide power switch to turn off

### 6.3 Interface and Buttons

#### 6.3.1 Interface Illustration

The interface includes and shows status display, model information, the information of material calibration group, testing display, the list of testing result and the information list of testing result shown in figure 6-3

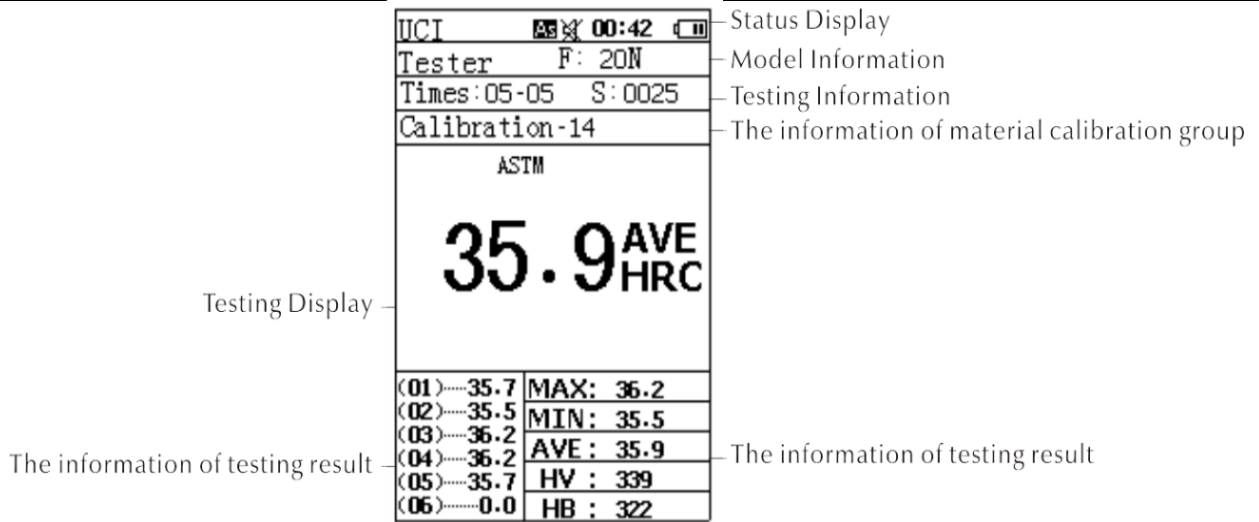
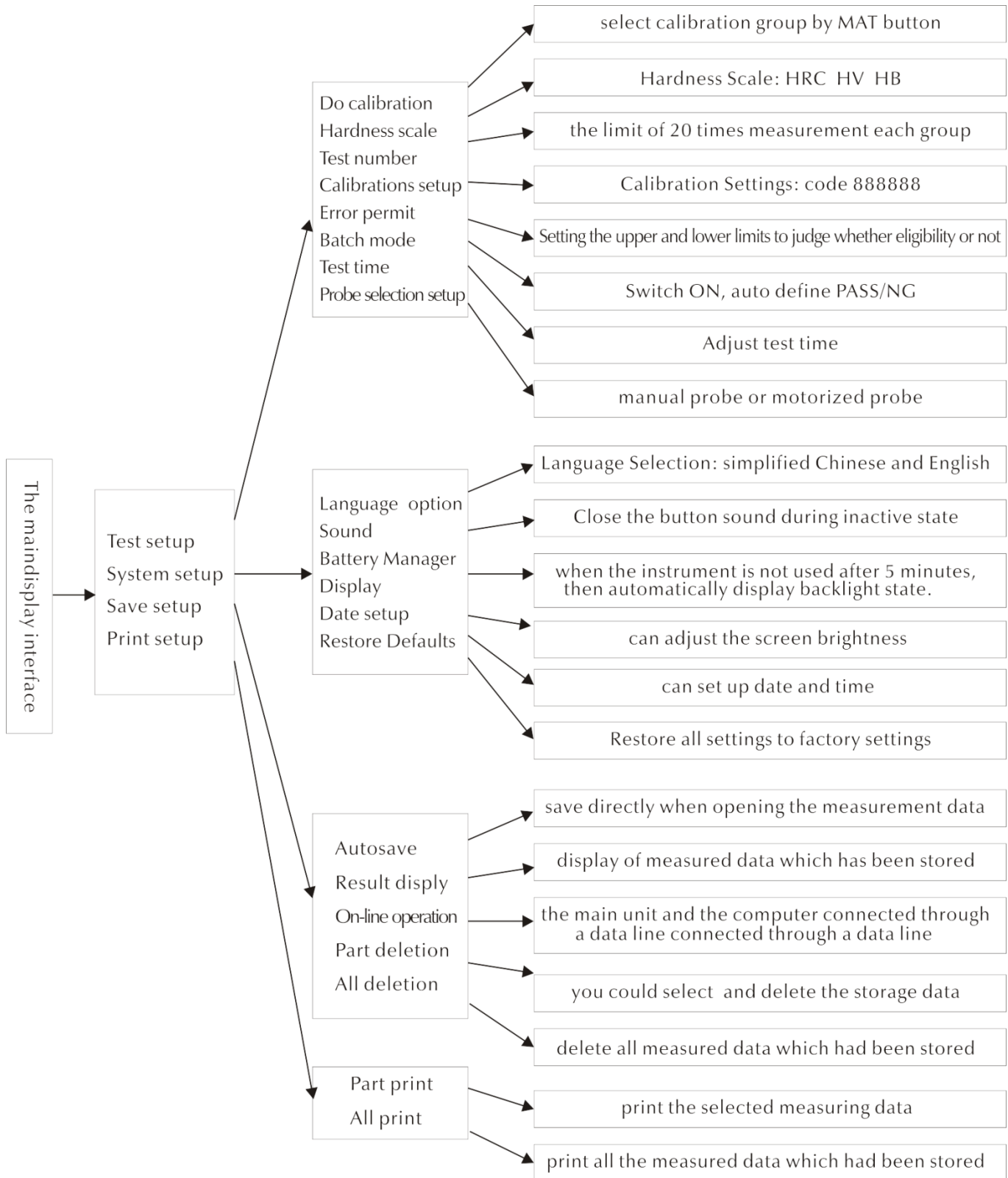

Fig 6-3

- Status Display-- Automatically save opening display, press buzzer buttons to display, the system time, real-time situation of battery power.
- Model Information -- the probe type F:20N said its test force 20N, which is HP-2K probe.
- The testing information -- Times: 05-05 said that this group measurement need to be measured 5 times to obtain the average value, S: 0025 said saving in storage settings →twenty-fifth groups in result display.
- The information of material calibration group -- Calibration-14 said that the present measurement is invoking from the fourteenth groups of the calibration data, total 20 groups of calibration data.
- Testing display – shows hardness value for each measurement and the average value.
- The list of testing result--the list display of one group data in each measurement
- The information of testing result-- MAX said the group measured maximum, MIN said the group measured minimum, AVE represents the average of this group, HV, HB said HRC scale measurement value change to Vickers hardness and Brinell hardness value.

## 6.4 Menu Structure



## 6.5 Test Setting

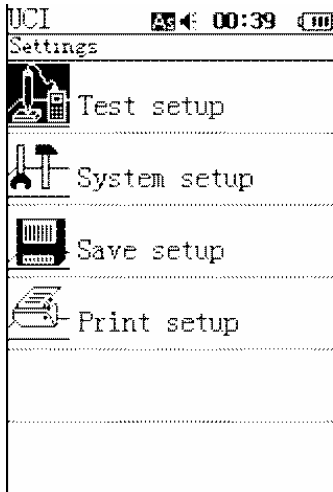

Fig 6-4-1

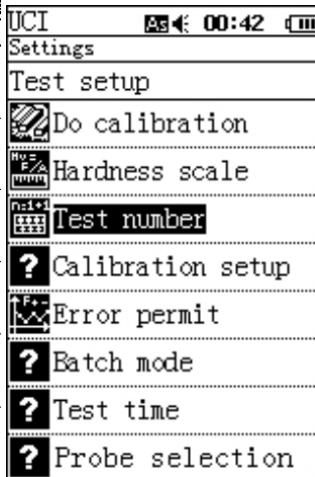

Fig 6-4-2

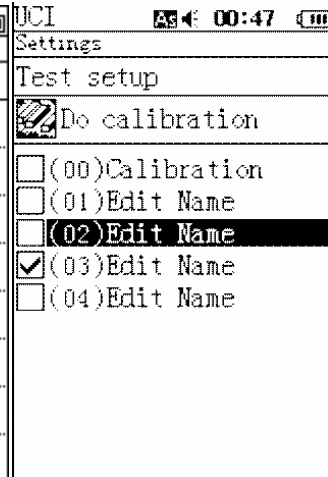

Fig 6-4-3

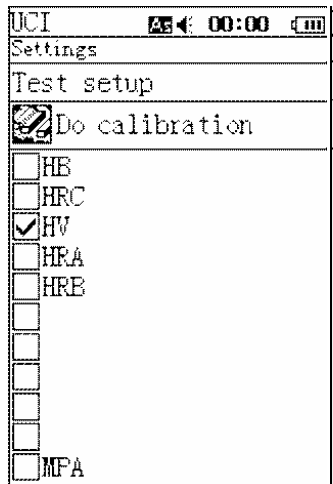

Fig 6-4-4

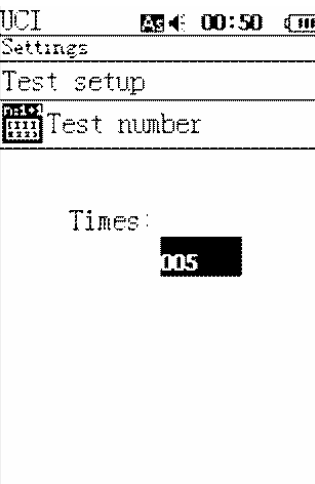

Fig 6-4-5

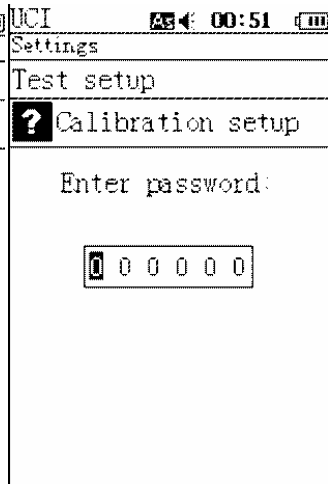

Fig 6-4-6

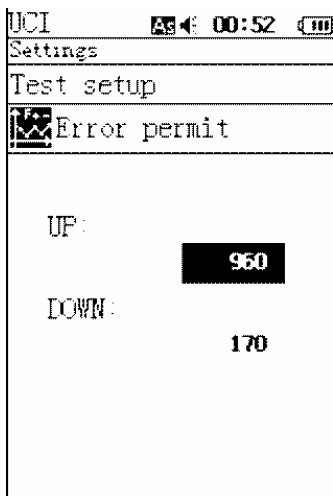

Fig 6-4-7

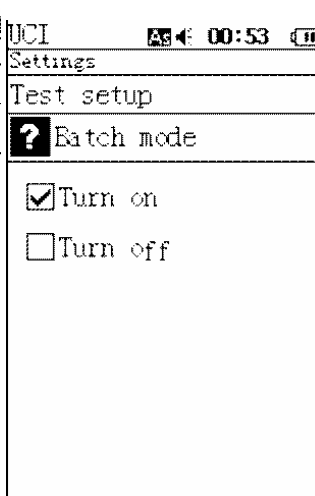

Fig 6-4-8

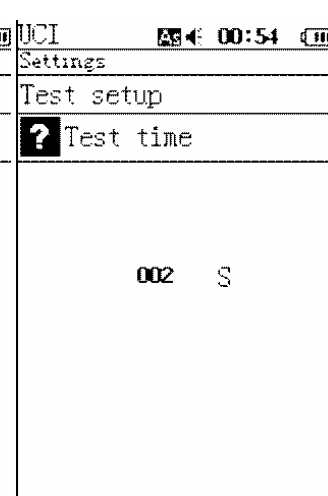

Fig 6-4-9

---

### 6.5.1 Set of Calibration

Select the similar calibration data with the material of measured sample, press MENU button into the interface of test setting, press ETR button into the interface of setting, then press button ETR enter calibration selection, press MAT button in calibration group to select shown figure 6-4-3. Also could view the other calibration data in calibration groups through pressing ETR button shown figure 6-4-3.

### 6.5.2 Set of Scales

Press SCALE button in the main interface to select the suitable hardness scale shown figure 6-4-4.

### 6.5.3 Start Measuring

Press ETR button to begin hardness measurement.

### 6.5.4 Set of Test Numbers

In measurement time group ,plus or minus the times through 【←】 【→】 buttons shown figure 6-4-5.

### 6.5.5 Set of Error

In tolerance limits group, 【↑】 【↓】 button to adjust the limits of the upper and lower value shown figure 6-4-7. There will be showed unqualified information in the main interface . (This function is only for SU-200, D10 verifies current measurement whether valid in calibration system and compensation setting, see calibration fig5.5, UP and DOWN used to set tolerance limits, detail explanation refer 6.9 calibration setting )

### 6.5.6 Set of Batch Measurement

In Fig 6-4-8, press 【↑】 【↓】 to select batch measurement on/off, in on situation, the second measurement will display judgment information.

### 6.5.7 Set of Measurement Time

In Fig 6-4-9, press 【←】 【→】 to adjust measurement time in one measurement. Recommended time for 5kgf and 10kgf should be 4 to 5 seconds.

### 6.5.8 Probe Selection Setup

In Fig.6-5-10, Press 【↑】 【↓】 to select probe type, Press 【ETR】 or 【MENU】 back to previous menu.

“Default” means use manual probe, supports any force of manual probes, after connected the screen will show probe force

“MP-300/500/800/100” means 3N/5N/8N/10N motorized probe, it cannot automatically recognize probe info, but needs set in the main unit.

Note: before measurement, please make sure probe setup is correct.

## 6.6 System Setting

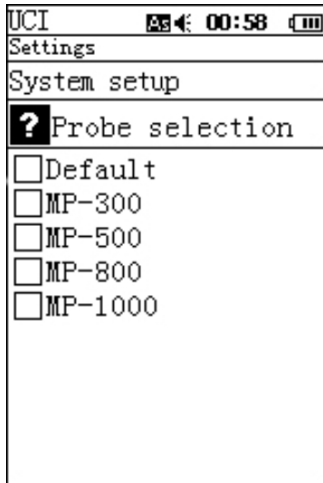

Fig 6-4-10



Fig 6-4-11

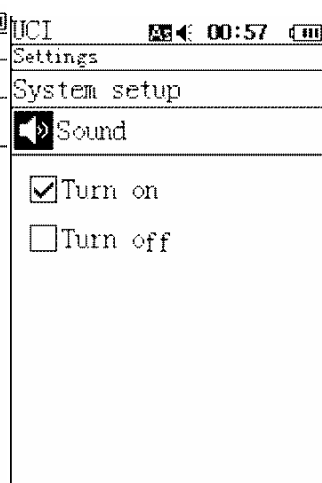

Fig 6-4-12

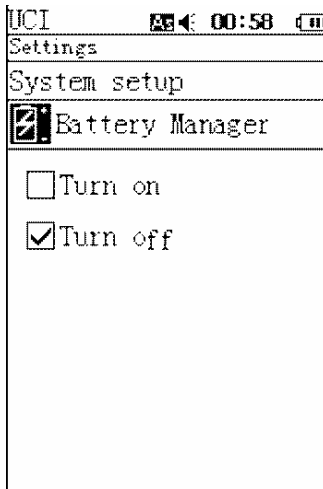

Fig 6-4-13

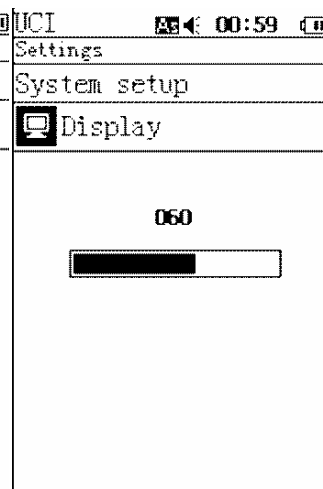

Fig 6-4-14

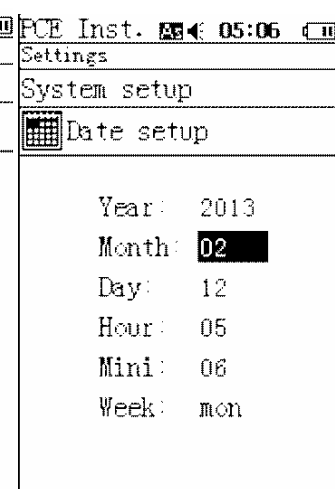

Fig 6-4-15

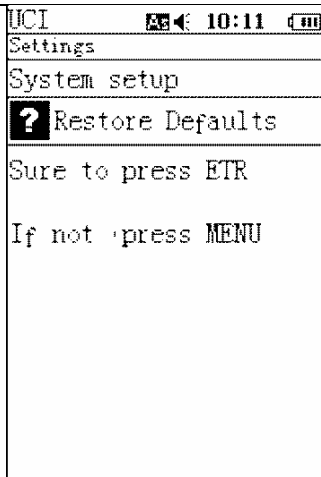

Fig 6-4-16

### 6.6.1 Set of Language

**Language option**——By press **【↑】 【↓】** to choose language (Chinese, English, or others) Fig 6-4-11.

### 6.6.2 Set of Voice

**Voice**——By press **【↑】 【↓】** to ON/OFF voice, in OFF condition, only off press voice, others operation voice is normal, Fig 6-4-12 .

### 6.6.3 Battery Manage

**Battery Manage**——By press **【↑】 【↓】** to ON/OFF, in ON condition without any operation in 5min, instrument will auto power off, same circumstance when in recharging, it is normal. If in OFF condition, the instrument will be always in standby time until use off the battery, we have to manually turn off. This mode is used in outer power supply. Fig 6-4-13.

### 6.6.4 Display Setting

**Display**——By press **【←】 【→】** to adjust contrast of screen, show as Fig 6-4-14; we also can press **【←】 【→】** to adjust screen contrast in main interface.

### 6.6.5 Date Setting

**Date Setting**——Press **【↑】 【↓】** switch, press **【←】 【→】** setting, Fig 6-4-15。

### 6.6.6 Factory Reset

**Factory Reset**——In Fig 6-4-16, Press **【ETR】** restore factory settings according to steps, factory reset will clean calibration data, test settings, system settings, testing results, without special situation, please do not use this function.

## 6.7 Memory Setting

Memory Setting includes: Auto Save (Fig 6-4-18) , **Result display** (Fig 6-4-19) , On-line Operation (Fig 6-4-20) , **Part deletion** (Fig. 6-4-21) , **All deletion** (Fig 6-4-22) . This part is mainly used for storage display and management of the measured data result

Press **【↑】** **【↓】** to switch and select, press **【ETR】** enter submenu, Press **【MENU】** quit.

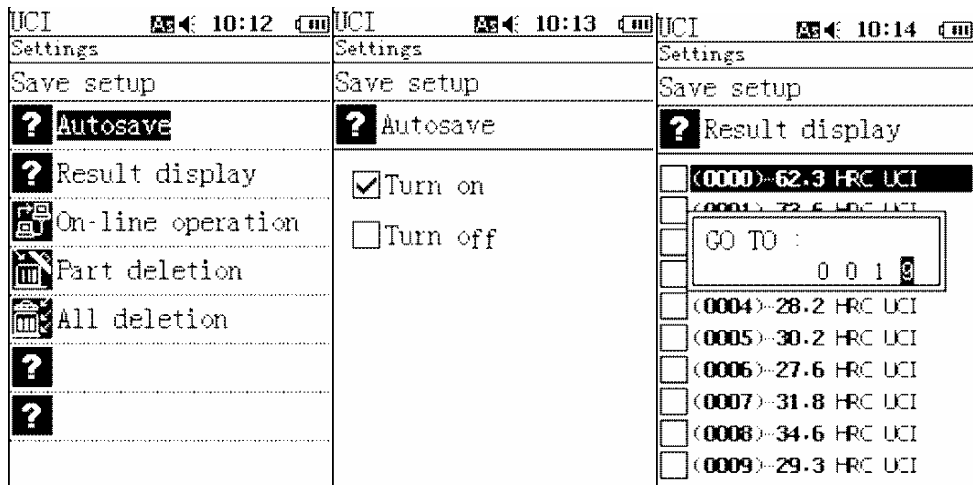

Fig 6-4-17

Fig 6-4-18

Fig 6-4-19

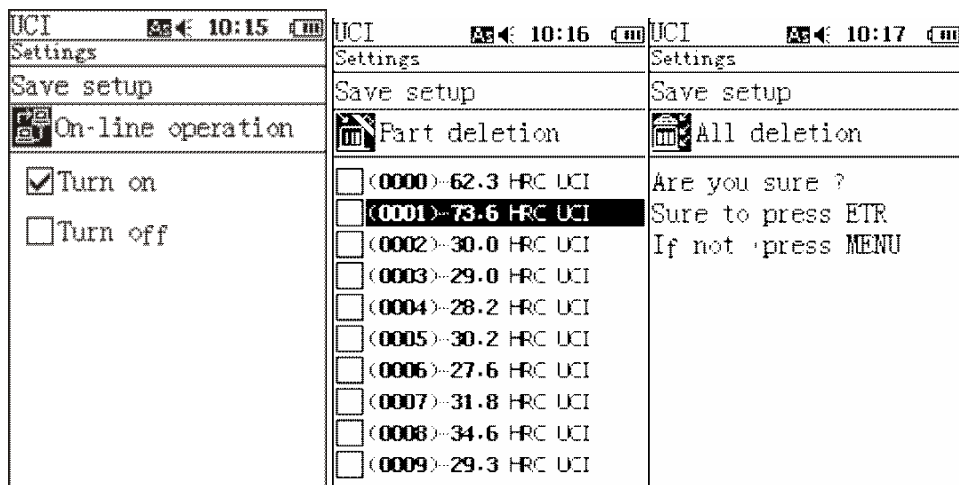

Fig 6-4-20 Fig 6-4-21 Fig 6-4-22

### 6.7.1 Auto Save Setting

**Auto Save**—By press **【↑】** **【↓】** to switch ON/OFF; In ON status, measuring data will be saved automatically.

Fig.6-4-18

## 6.7.2 Review Results

**Results display**—By press **【↑】** **【↓】** to select, or press **【SCALE】** to positioning and review specific data Fig. 6-4-19

## 6.7.3 On-line Operation

**On-line Operation**—The measurement data are sent to the super receiving end of the computer through the super terminal , Fig 6-4-20, computer hyper terminal, see part 6.11

## 6.7.4 Partial Delete

**Part deletion**—delete the pages of measurement data result , Press **【↑】** **【↓】** to select data, Press **【SCALE】** to delete them, Fig 6-4-21.

## 6.7.5 Delete All

**All deletion**—delete all the measurement data, Fig 6-4-22, it will take a few minutes to finish.

## 6.8 Printing Setting

### 6.8.1 Partial Print

show how to connect printer to print measuring data , Press **【ETR】** enter part print interface , press **【MAT】** to print data not selected, Fig. 6-4-24;

### 6.8.2 Print All

If want to print all data, press **【ETR】** enter printing interface, press send to print, Fig 6-4-25.

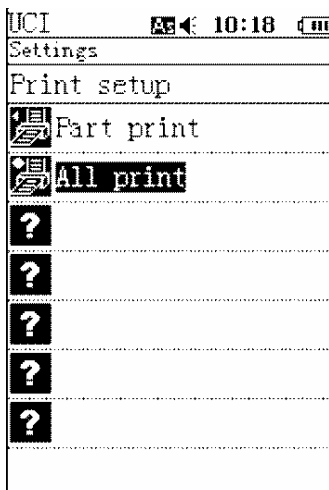

Fig 6-4-23

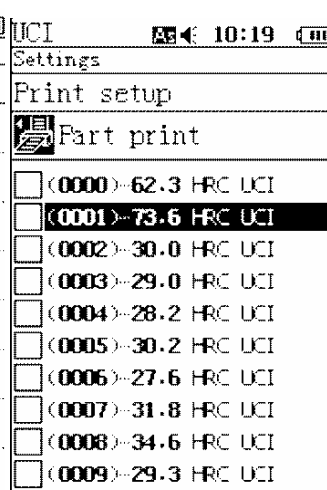

Fig 6-4-24

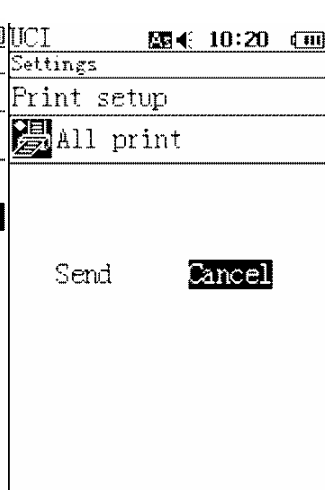

Fig 6-4-25

---

## 6.9 Calibration Steps

### 6.9.1 Calibration Reasons:

- If in the process of the hardness tester verification on the reference hardness block the readings are stable but differ from the nominal value of the reference hardness block;
- after long period of storage (more than 3 months);
- After intensive operation (more than 200.000 measurements for ultrasonic probe;
- In case of considerable change in the conditions of operation (ambient temperature, humidity etc.)

### 6.9.2. Calibration Preparation

For calibration along the whole “C” Rockwell scale, TWO reference hardness blocks are required with the values of  $(25 \pm 5)$  HRC and  $(65 \pm 5)$  HRC.

If you do not use the whole range of “C” Rockwell but only the range of 20--40 HRC, performs the calibration on reference hardness blocks with the values of  $(25 \pm 5)$  HRC and  $(45 \pm 5)$  HRC.

Same principle for Vickers hardness blocks.

Note: for special cases, only one block for calibration is acceptable.

### 6.9.3. Calibration Example:

1) Two standard hardness blocks (High and Low each 1 piece)

In main interface press **【MENU】** Setting interface, Fig 6-9-1, Then press **【ETR】** enter fig. 6-9-2, by press **【↓】** switch to calibration setting, Press **【ETR】** enter calibration setting, password (888888, by press **【↑】** **【↓】** change numbers), then press **【ETR】** enter calibration interface Fig. 6-9-4, Press **【↑】** **【↓】** switch calibration save position, Calibration-00 is default calibration group, users can add calibration data from 01group.

UCI 00:51	UCI 10:29	UCI 10:23
Settings	Settings	Settings
Test setup	Test setup	Test setup
? Calibration setup	Edit Name -01 (HV)	Edit Name -01 (HV)
Enter password:	6 times for: TEST-H	6 times for: TEST-L
0 0 0 0 0 0	TEST-L: 738	TEST-L: 738
	Normal-L: 738	Normal-L: 738
	TEST-H: 714	TEST-H: 738
	Normal-H: 714	Normal-H: 738
	Up: 000	Up: 000
	Down: 000	Down: 000
	F: 20N HZ:default	F: 20N HZ:default
	8710 6740 7080	735 690 722
	6660 7000 6660	841 731 714

Fig 6-9-1

Fig 6-9-2

Fig 6-9-3

UCI 10:23	UCI 10:29
Settings	Settings
Test setup	Test setup
Edit Name -01 (HV)	Edit Name -01 (HV)
6 times for: TEST-L	6 times for: TEST-H
TEST-L: 738	TEST-L: 738
Normal-L: 738	Normal-L: 738
TEST-H: 738	TEST-H: 714
Normal-H: 738	Normal-H: 714
Up: 000	Up: 000
Down: 000	Down: 000
F: 20N HZ:default	F: 20N HZ:default
735 690 722	8710 6740 7080
841 731 714	6660 7000 6660

Fig 6-9-4

Fig 6-9-5

Take Edit Name-01 as an example, in Fig 6-9-4, Press **[MAT]** enter measurement status, press **[→]** switch to TEST-L (low value block) ,test 6 times, instrument will show average value Fig.6-9-4, then press **[MAT]** enter measurement status, press **[→]** switch to TEST-H (high value block) ,test 6 times, instrument will show average value Fig.6-9-5, then press **[MENU]** quit to modify standard value status, for example, if low value block standard value is 230HV, high value is 840HV, then by press **[←]** **[→]** modify Normal-L at 230, then press **[↓]** switch to Normal-H, press **[←]** **[→]** modify at 840, when value is big, please firstly press **[SCALE]** to select digits, press **[MENU]** quit and finish calibration.

Select calibration group: back to test setup, select Do Calibration and press [ETR] enter to calibration group list, press **[↑]** **[↓]** to choose specific calibration group, press [MAT] to confirm selected one, then press [MENU] back to main interface and start measurement.

---

In Fig6-9-3, the UP and Down value also can be modified, use of HZ: default see part 7, special materials calibration.

Cancel Calibration Data: during calibration, if come bad data, but do not finish the whole calibration process, Press [SCALE] to cancel previous data; while if calibration process is finished, then press [SCALE] can cancel calibration data, then re-calibrate.

Save Calibration data: Press [MENU] to save and quit.

## 2) One hardness block calibration

Calibration step is same with Two standard hardness blocks, the only difference only choose mode in TEST-L, get 6 measurement data, modify Normal-L value, no need to calibrate TEST-H and modify Normal-H.

## 3) Tolerance limit setting (Batch Mode)

Tolerance limits setting, enter up and down values, for example UP is 250, Down is 240, each time when you measure hardness, instrument will determine if hardness value in the range, if not, it will display NG, it can be set after calibration Normal-H, press 【↓】 modify UP and DOWN value.

If not set well during calibration, enter calibration interface, and press 【MAT】 then 【MENU】 to set UP and DOWN value

This operation shall be carried out only by highly skilled technicians and the measurement error must be under JB/T9377-2010 when test standard hardness block, see details in this manual part 6.10.

If error exceeds JB/T9377-2010 requested, then repeat mentioned calibration steps and cover previous data.

## 4) Calibration Difference between Manual probe and Motorized probe

Above steps are for manual probe calibration, when use motorized probe, enter calibration interface, the settings are same, difference as follows:

- a) During calibration, press [MAT] can switch to “TEST-L”, the first measurement does not need press top button, follows measurement need. No need Press [→]switch to TEST-L
- b) After calibration and quit, initial enter main interface with one auto measurement.

Note: Put probe vertically on surface of hardness block before press [MAT]

## 5) Calibration of given hardness value materials

Calibrate a kind of given hardness value material into Ultrasonic hardness tester calibration group, the step is

---

same with using hardness blocks, the different is here we use a kind of material which given hardness value by others bench hardness tester while not standard block.

#### 6) Calibration Notice:

▲ When in calibration interface, first press [MAT], then vertically contact probe with standard block, if no reaction, take up probe and press [MAT] again, get 6 measurements.

▲ If shows ↑, means hardness value exceeds max value of this hardness scale; shows ↓, means hardness value lower than tested hardness scale.

▲ Advise modify name of calibration by probe type.

#### 7) Special Materials Calibration

As the elasticity modulus are different by metal materials, when test aluminum, copper and alloy, it will show higher value than its fact.

Below is an example for how to calibrate these materials:

Aluminum specimen with hardness at 200HV, no calibration the result is 700HV, we can apply normal calibration steps, but not stable. In this case, we consider use special calibration HZ: default, the steps is same with the first part of calibration, to the step press [MAT] measurement status, right up corner with , press **【→】** to **【6 times for: TEST-L】**, test one time, suppose the result is 705HV, according to 10HV = default 1000 to adjust, then set default to 50000, and press [SCALE] to delete 705HV, then test one measurement, the value is 240HV, very close to its real hardness.

Then test 6 times and get average value, set Normal-L at 200, and save it.

Until now, the calibration is finished.

Note: for normal materials, do not use this function.

### 6.10 Error and repeatability request for ultrasonic hardness tester in standard of JB/T9377-2010

Get 6 measurements of each standard block, delete the first one, total valid is 5 measurements.

Rockwell scale Error  $\delta$  according to formula (6-10):

$$\delta = H_i - H \quad (6-10)$$

Brinell and Vickers Error  $\delta'$  according to formula (6-11):

$$\delta' = \frac{H_i - H}{H} \times 100\% \quad (6-11)$$

Notice:

$H_i$ ---- average of 5 measurements;

H----Nominal value of standard block

Rockwell scale repeatability  $b$  according to formula (6-12):

$$b = H_{\max} - H_{\min} \quad (6-12)$$

Brinell and Vickers scales repeatability  $b$  according to formula (6-13):

$$b = \frac{H_{\max} - H_{\min}}{H_i} \times 100\% \quad (6-13)$$

Notice:

$H_{\max}$ --- Max value in 5 measurements;

$H_{\min}$ ---- Min value in 5 measurements.



Error and repeatability request for ultrasonic hardness tester in standard of JB/T9377-2010 (table 6-10)

Error and repeatability request for ultrasonic hardness tester in standard of JB/T9377-2010		
Hardness Range	Max permit error	Max permit repeatability
150HBW ~ 350HBW	±15%	15%
> 350HBW ~ 540HBW	±10%	10%
150HV ~ 200HV	±15%	15%
> 200HV ~ 400HV	±10%	10%
> 600HV ~ 999HV	±3%	3%
25HRC ~ 35HRC	±2.0HRC	2.5HRC
40HRC ~ 50HRC	±2.0HRC	2.5HRC
55HRC ~ 65HRC	±2.0HRC	2.5HRC

Table 6-10

---

## 6.11 About Battery

There is rechargeable battery (4.2V, 4800mAh) installed in main unit. When the battery runs out, the upper right corner of the main interface will display  to remind you battery charging in time. Insert one end of charger into the left socket of instrument, plug in the 220V electricity and charging. Fully recharging time is 8 hours, while not less than 4 hours for one charging. When the charging is completed, the upper right corner of the main interface will display , please unplug the charger, then you can open the instrument to operate.

## 6.12 Data Transmission

Connect instrument and computer by data transmission cable, four pins socket connect with instrument and the other side connect with computer host.

In Win XP system, click start -> program -> accessory -> communication -> hyper terminal, set up new hyper terminal, then name it. Select COM port, Baud rate is 115200, the others information no needs to be modified, show as fig6-1-1. When everything is ready, then we can send data to computer.

In win7 system, there is no hyper terminal, we have to install one, note the Baud rate is 115200, others no need to change.

## 7. Troubleshooting

Failure phenomenon	Analysis	Settlement
Power on Failure	Battery use out or damaged	Recharging or replace new battery
No measuring value	<ol style="list-style-type: none"><li>no press ETR button.</li><li>Probe or socket pin of main unit is crooked.</li></ol>	<ol style="list-style-type: none"><li>Hand the probe up and then press ETR button again.</li><li>Check if the data line connected with the probe and main unit is problem, if the socket pin and pinhole is damaged.</li></ol>

<p>1.no value after measurement but display ↑↓, 2.no response or response after a long time</p>	<p>1.The hardness value of the tested sample is higher or lower than the scale range when using. 2. First use the probe to put the specimen and then press ETR button ,sometimes this problem will be happened ,the power is too strong pressed on the probe.</p>	<p>1.Change the hardness scale and then measuring again .If still have problem ,please measure on the desktop hardness testers to check the result. 2.First press ETR button ,probe gently touch the specimen in vertical direction, no need a strong power to press .</p>
<p>1. Measured value is not correct.</p>	<p>1. The probe is damaged or the sample is too rough.</p>	<p>1 Please check the probe head is damaged; if the tested value of the specimen's standard hardness block is stable ; calibrate again ; use the measured material to calibrate .</p>
<p>1.Deviation measurement</p>	<p>1.As the structure positions are changed when disassembly instrument , leads to the inaccuracy data of calibration groups, or the big difference between the calibrated material and tested material, (such as the original calibration in instrument is steel material but now you change aluminum material to measure.</p>	<p>1. Please try again with the tested samples made of the same material specimen for calibration, and then measure.</p>

## 8. Maintenance

8.1 Before and after measurements, please use the non-woven fabric with a little alcohol to wipe the probe head gently and clean the dirty mark. After measurements, use clean cloth to clean the main unit and the surface stains of the probe.

8.2 Recharging before long time no operation.

8.3 Please put the probe cap on the probe when no using, because the diamond indenter on probe is hard and brittle, easy to be fell off when meeting violent impact . Please put the main unit and accessories into the assorted tool box.

---

## **9. Warranty Attention**

- DGC provides 2 years warranty for main unit only for quality problem, the others accessories are not under warranty. Refer packing list of D10.
- Please show invoice and warranty card in case need repair.
- we ask for charges for accessories not under warranty

## **10. Storage/Transportation Attention**

Storage should be far away from the vibration, corrosion, moisture, dust, also should be stored at a normal temperature and humidity. Please put in the original packing box before transportation to avoid any damage.

Note: Operation manual will be updated without further notice, latest edition will be sent to customers by email timely.